

RECORD SETTINGS

format: HQ 1920/23.98P (23.976) color: 4:2:0 (internal SxS)
shutter: 180° optional S-Log
TC: NDF file: XDCAM EX

QUICK SET-UP

SWITCH/BUTTON SET

① SET shutter SHUTTER **ON**
② SELECT ISO GAIN L 400 · M 800 · H 1600
③ SELECT color temp. TUNGSTEN **PRST 3200K**
④ DAYLIGHT set ATW ③ to **PRST**
 set (button) 5600K

MENU

- RESET to factory
 - ④ OTHERS ▶ All Reset ▶ Execute
- SET shutter
 - ④ CAMERA ▶ Shutter ▶ Mode: Angle
- SET format
 - ④ OTHERS ▶ System ▶ Format: HQ 1920/23.98P
- SET LCD display
 - ④ LCD/VF SET ▶ Marker ▶ Aspect Marker: Line
 - ▶ Aspect Select: 1.85:1
 - ▶ Gain Setting: ISO
 - ▶ Display On/Off
- FORMAT media
 - ④ OTHERS ▶ Format Media ▶ Media(A)
 - ▶ Media(B)

ADDITIONAL FUNCTIONS

S&Q knob to Jog dial (menu navigate)

▶ press/hold CANCEL ② ▶ press S&Q knob ②

Shutter

CAMERA ▶ Shutter ▶ Mode: **Angle**
▶ Shutter Angle: 216° · **180°** · 172.8° · 150° · 144° · 90°
86.4° · 72° · 45° · 22.5° · 11.25°

Frame Rate (slow & quick motion)

CAMERA ▶ S&Q Motion ▶ Format: **HQ 1920/23.98**
(S&Q **NOT** set to jog dial) ▶ press S&Q ② ▶ Execute (blue outline illumin.)

LCD display

LCD/VF SET ▶ Peaking (focus assist) ▶ Color: White · Red · Yellow · Blue
▶ Level: High · Mid · Low
▶ Marker ▶ Setting: On
▶ Safety Zone: Off
▶ Center Marker: Off
▶ Aspect Marker: Line
▶ Aspect Select: 2.35:1 · **1.85:1** · 1.66:1 · 15:9 · 14:9 · 13:9 · 4:3
▶ Display On/Off ▶ AudioLevelMeter: Off
▶ TLCS Mode: Off (Total Level Control System)

Define Clip Name

OTHERS ▶ Clip ▶ Auto Naming: Title
▶ Title Prefix: user defined ie. **1A_**
▶ Number Set: user defined ie. **0001**

Timecode / User Bit

TC/UB SET ▶ Timecode ▶ Mode: Preset
▶ Run: Rec Run vs **Free Run**
▶ Setting: user defined ie. **military time of day**
▶ User Bit ▶ Mode vs. Fix
▶ Setting: user defined ie. **date**
▶ TC Format ▶ NDF (set from format type)

S-Log

PICTURE PROFILE ② ▶ SEL ▶ PP: STANDARD
▶ SET ▶ Profile Name user defined ie. **S-Log**
▶ Gamma ▶ Select: S-Log

- ▶ **CREATE Disk Image of SxS card**
- ▶ **do not force SxS card**

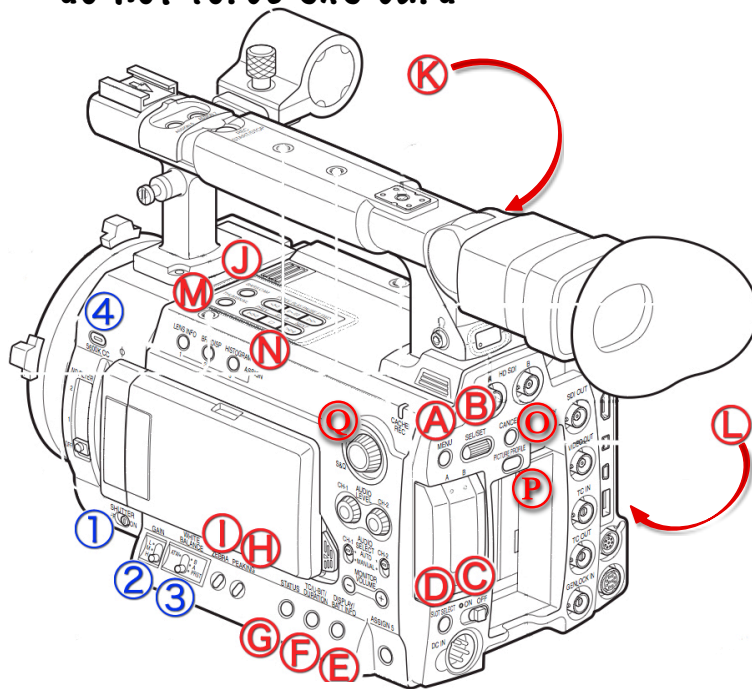

F3 BUTTON/SWITCH

① SHUTTER	(switch)	OFF ON	exposure time (<i>motion blur</i>)
② GAIN	(switch)	L M H	light sensitivity (<i>signal gain</i>) L(400iso) · M(800iso) · L(1600iso)
③ WHITE BALANCE	(switch)	PRST A B	PRST(3200K) · A(user) · B(user)
④ 5600K CC	(toggle)	OFF ON	daylight color correction (when WB switch PRST)
A MENU	(toggle)	OFF ON	
B SEL/SET	(toggle)	scroll set	navigate menu
C POWER	(switch)	ON OFF	
D SLOT SELECT	(toggle)	(A) (B)	
E DISPLAY/BATT INFO	(toggle)	show hide	
F TC/UB/DURATION	(toggle)	TC UB	
G STATUS	(toggle)	show hide	
H PEAKING	(toggle)	ON OFF	image contour (<i>focus assist</i>)
I ZEBRA	(toggle)	ON OFF	luminance (<i>exposure assist</i>)
J BARS/CAM	(toggle)	Camera Color Bars	
K EXPAND FOCUS	(toggle)	ON OFF	digital zoom (<i>focus assist</i>)
L REC START/STOP	(toggle)	record	
M THUMBNAIL	(enter)	clip view	playback recorded clip files
N STOP	(exit)	clip view	
O CANCEL			
P PICTURE PROFILE			
② S&Q	(adjust)	frame rate	slow & quick motion

TIME CODE JAM

- connect cable ▶ F3 TC Out (BNC) ▶ 702T TC IN (5pin Lemo)
- set F3 TC ▶ TC/UB SET ▶ Timecode ▶ Run: **Free Run**
- set 702T TC ▶ menu 42: TimeCode Mode: FreeRun-JamOnce
▶ menu 45: TimeCode: JamRXTX [ENTER]